

NOTES

1. CO-ORDINATION OF THIS INSTALLATION WITH HEATING, VENTILATION, AIR CONDITIONING & ELECTRICAL WORK IS BY OTHERS.
2. RAILTECH REQUIRES WRITTEN APPROVAL OF ALL SHOP DRAWINGS BEFORE STARTING PRODUCTION.
3. CUT-OUTS FOR SPRINKLERS, SPEAKERS, COLUMNS, FLOOR SLABS, ETC. ARE DONE IN FIELD BY OTHERS.
4. ALL OVERALL DIMENSIONS MUST BE VERIFIED IN FIELD BY OTHERS.

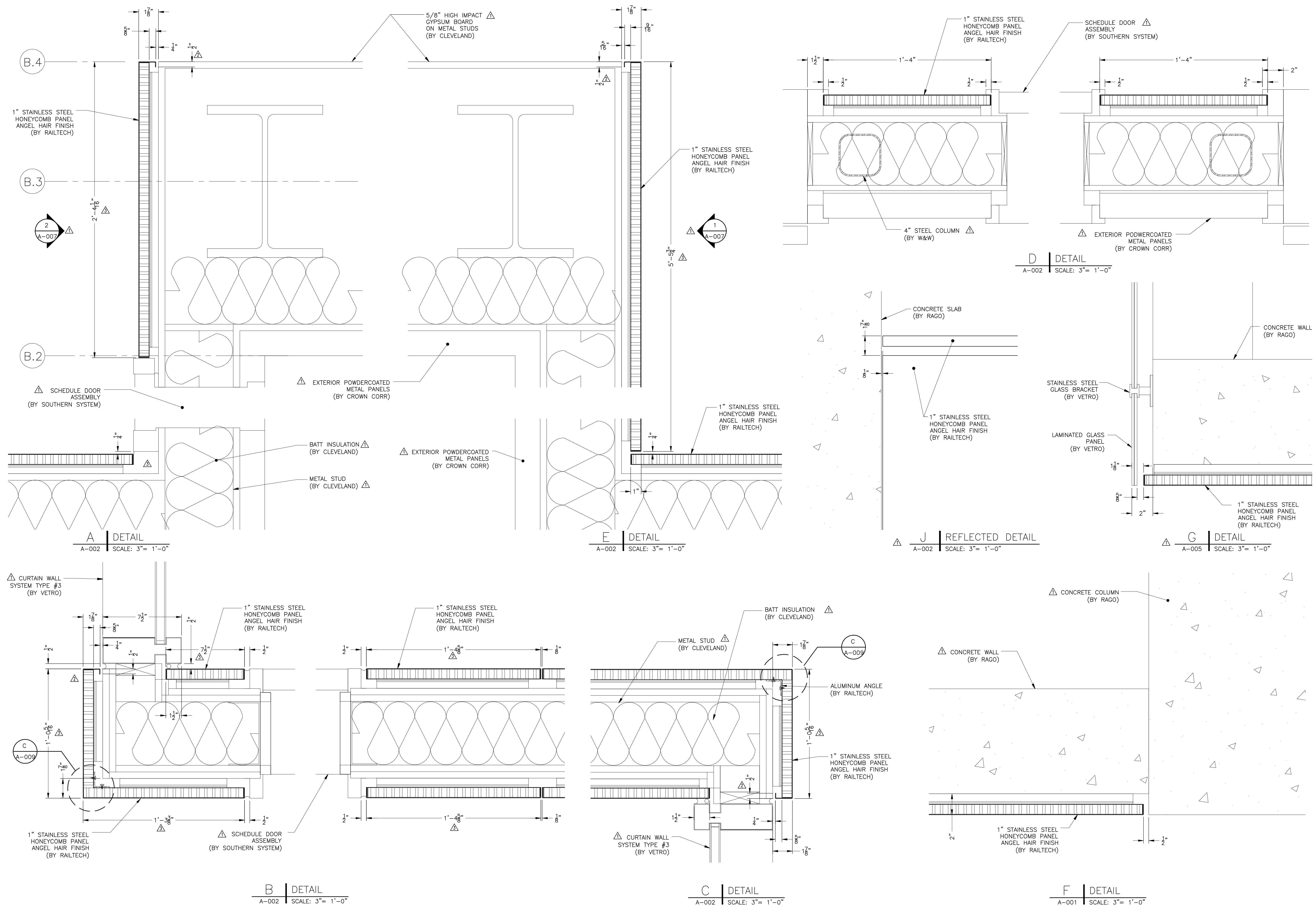

REVISD AS REQUESTED	J.A.	21.05.04
MODIFIED DETAILS A, B, C & E	J.A.	29/01/03 M.M.
MODIFIED PANEL DIMENSION, DRAWING NOTES AND ADDED DETAILS G & J.	J.A.	15/08/03 M.M.
REV.	DESCRIPTION	BY DATE APP

LAMCEL
entrances

Part of the Railtech Architectural Group
 (514)457-4760 www.lamcel.com info@lamcel.com

client	project	date
	GEORGE BUSH INTERCONTINENTAL AIRPORT HOUSTON TEXAS APM STATION AND PLATFORM	APRIL 28 2003
	contract number	verified
	10171	
	drawing title	approved
	PLAN DETAILS	M. McDONALD MAY 15 2003
drawn	scale	revision
J. ALBERT	AS NOTED	A-008 3